

THIS DRAWING IS UNPUBLISHED. RELEASED FOR PUBLICATION .19  
 BY AMP INCORPORATED. ALL RIGHTS RESERVED.

LOC	DIST	REVISIONS			
P	LTR	DESCRIPTION	DATE	DWN	APVD
AF	50	C	REL PER 063A-0316-01	13JUN01	JR KR

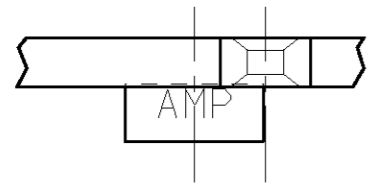

- 1 CONTINUOUS STRIP ON REELS WITH TERMINALS LOCATED ON 5.08±0.08 [.200±.003] CENTERS.
- 2 SLOT ACCEPTS 0.36-0.45mm [#27-#25] AWG COPPER MAGNET WIRE
- 3 IDENTIFICATION NUMBER 9 FOR WIRE SLOT SIZE.
- 4 0.002032 [.000080] MIN TIN PLATE OVER 0.00254 [.000100] MIN COPPER UNDERPLATE.

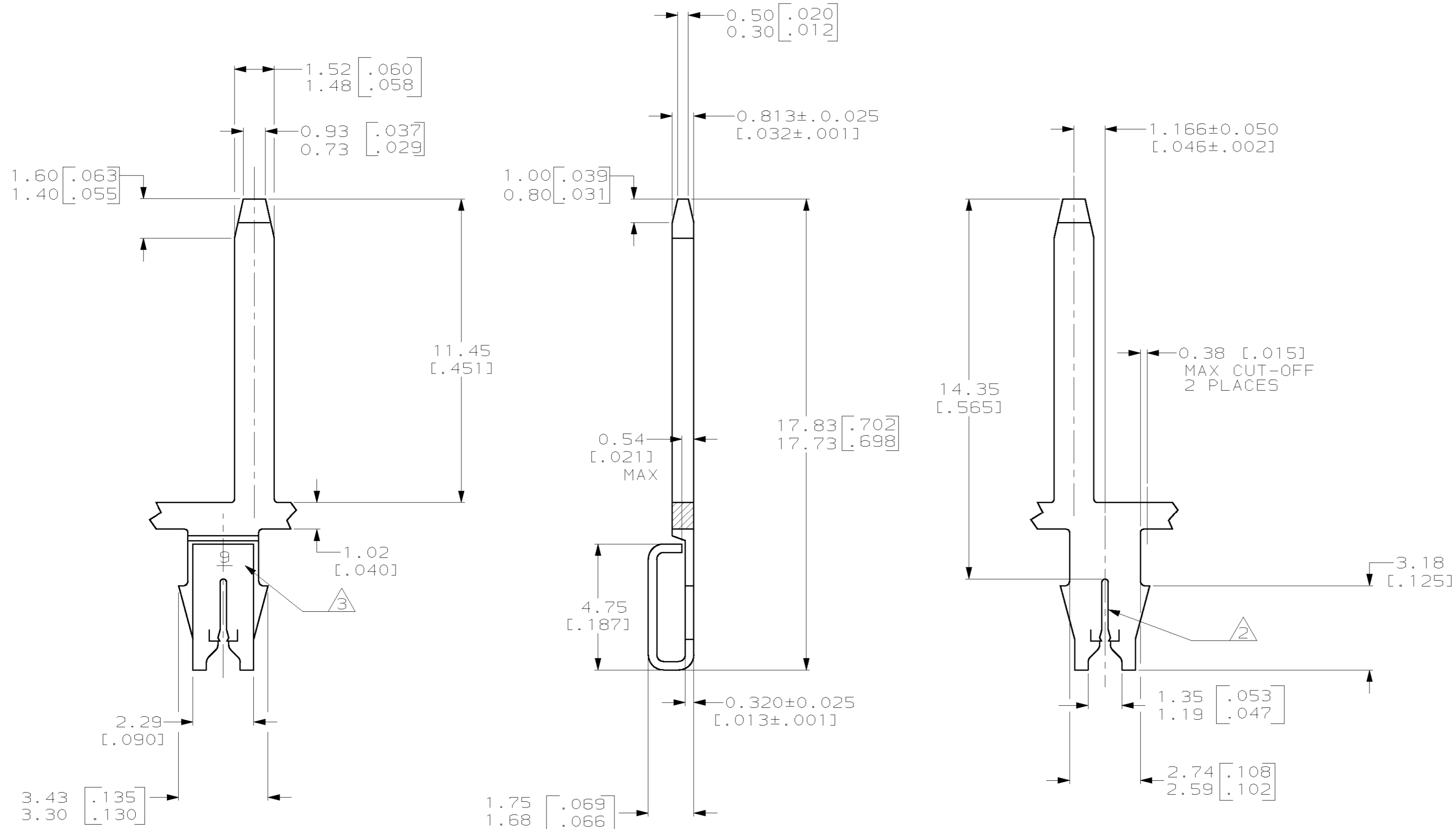

1217459-1  
PART NUMBER

THIS DRAWING IS A CONTROLLED DOCUMENT.		DWN MICHAEL S. FEHER 09AUG2000	AMP Incorporated Harrisburg, PA 17105-3608	
DIMENSIONS: mm (INCHES)		CHK KURT A. RANDOLPH 09AUG2000	AMP	
TOLERANCES UNLESS OTHERWISE SPECIFIED:		APVD KURT A. RANDOLPH 09AUG2000	TAB, 1.50 [.059] SERIES, RIGHT HAND, 187 SERIES MAG-MATE™	
0 PLC ±- 1 PLC ±- 2 PLC ±0.25 (.010) 3 PLC ±- 4 PLC ±- ANGLES ±- FINISH 4		PRODUCT SPEC 108-2012 APPLICATION SPEC 114-2069	SIZE A2	RESTRICTED TO -
MATERIAL H04 PRE-MILLED BRASS		WEIGHT -	CAGE CODE 00779	DRAWING NO 1217459
		CUSTOMER DRAWING		SCALE 8:1 SHEET 1 OF 1 REV C

1217459