

Outdoor Thermoelectric Cooler Assembly



Patent No.: US 9,360,240

Americas: +1.919.597.7300

Europe: +46.31.420530

Asia: +86.755.2714.1166

ets.sales@lairdtech.com

www.lairdtech.com

The AA Outdoor Cooler Series is an Air-to-Air thermoelectric assembly (TEA) that uses impingement flow to transfer heat. It offers dependable, compact performance by cooling objects via convection. Heat is absorbed and dissipated thru high density heat exchangers equipped with air ducted shrouds and brand name fans. The heat pumping action occurs from custom designed thermoelectric modules that achieve a high coefficient of performance (COP) to minimize power consumption.

This product series has been designed to pass rigorous Telcordia test requirements conducted by our customers, such as earthquake resistance, salt fog, wind-driven rain, high temperature exposure and dust contaminants. This is due to the selection of world-class components such as brand fans with the highest degree of environmental protection and lifetime guaranteed waterproof connectors, heavy-duty anodization on the high-density heat sinks, overheat protection, and double environmental seals for the thermoelectric modules.

FEATURES

- 100W capacity rated at $\Delta T = 9C$, $T_{ambient} = 32^{\circ}C$
- Wide operating temperature range of $-40^{\circ}C$ to $+55^{\circ}C$
- Telcordia GR-487-CORE tested and verified by customers when integrated in telecom outdoor enclosures
- Gaskets, connectors, and fans provide a NEMA 4 seal for the enclosure
- UL60950 and UL50 approval obtained by customers when integrated in telecom outdoor enclosure
- Environmentally friendly solid state operation – no compressor or CFC refrigerants
- Cooling and heating in the same unit; optional temperature controller reverses the polarity of current to generate heating

APPLICATIONS

- Outdoor telecom enclosures
- Outdoor kiosks and displays
- Harsh condition electronic cabinets
- Battery cabinets

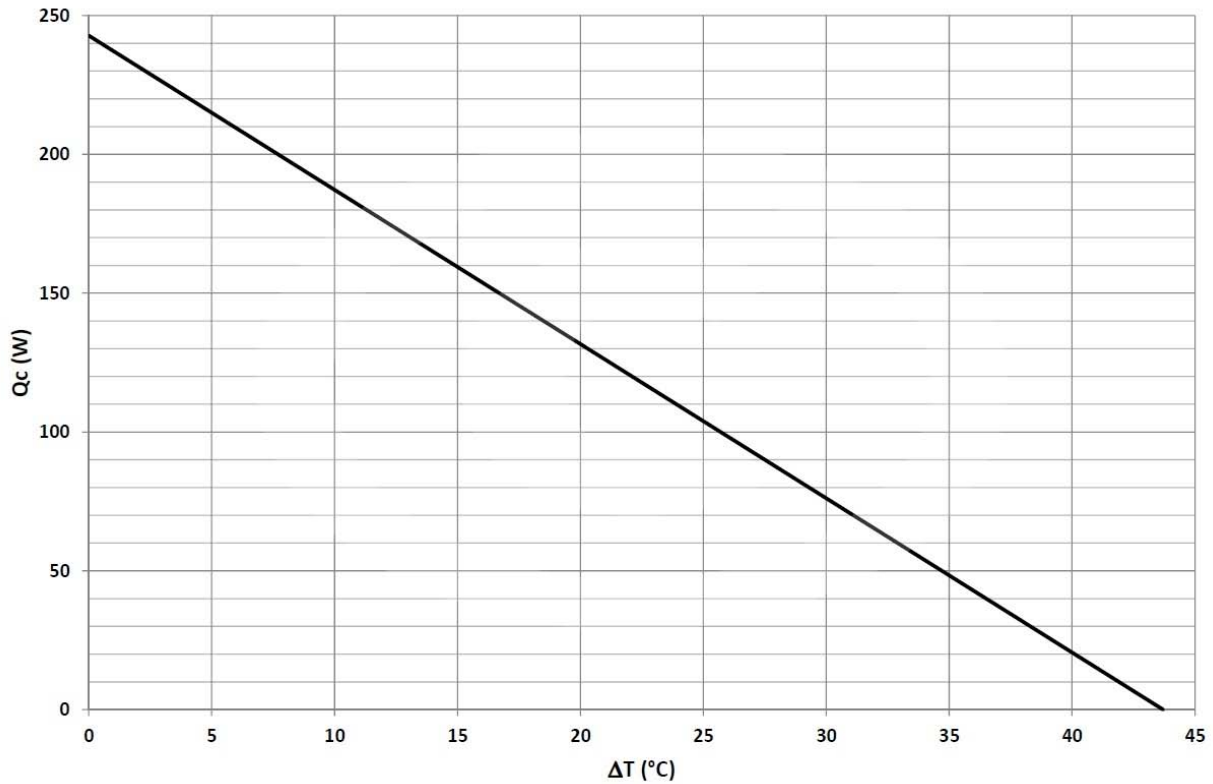

SPECIFICATIONS

TECHNICAL	
Technology	Thermoelectric (TE) modules, forced air, closed loop (non-mixing), filter-less, non-refrigerant
Cooling at dT = 0°C, and nominal / float voltage ¹	244/262 W (832/894 BTU/hr)
Heating ²	250W (853 BTU/hr)
Voltage (nominal / maximum) ⁶	24/28 VDC
COP (Coefficient of Performance)	85%
Grounding (all voltages)	Positive or negative
Current draw, ±10% (nominal / startup)	12.1/15.1 A
Weight	6.3 kg (16.9 lbs)
Panel mounting	Through (from external side)
Fan life (L10 at +40°C)	≥70,000 hours
Connector type (on unit / mating side)	Terminal block with cage clamps (AWG 28-12)
Hi-pot testing	707 VDC

ENVIRONMENTAL

Temperature range (external ambient) ³	-40°C to +55°C (-40°F to +131°F)
Temperature range (internal enclosure)	-20°C to +55°C (-4°F to +131°F)
Degree of protection, enclosure ⁴	NEMA 4 (IP55)
Degree of protection, unit internal side ⁵	IP54
Degree of protection, unit external side ⁵	IP54
Sound level (1m distance)	63 dB(A)
Over-Temp Thermostat ³	75°C ± 6°C (accessory)
Temperature range (external ambient)	-40°C to +55°C (-40°F to +131°F)
Temperature range (internal enclosure)	-20°C to +55°C (-4°F to +131°F)

Notes:

1. Cooling capacities at nominal / float voltage are rated at external temperatures of +35°C and +50°C respectively. Float voltage is defined at 27 VDC
2. Calculated heating capacity is rated at external temperature of -40°C, nominal voltage, and $\Delta T = -45^\circ\text{C}$.
3. Controller function shall not operate the external fan during heating mode.
4. The highest environmental protection level requires an external shroud and is defined as the protection level for the enclosure.
5. Rating for unit without protective shroud.
6. Max ripple 5%.

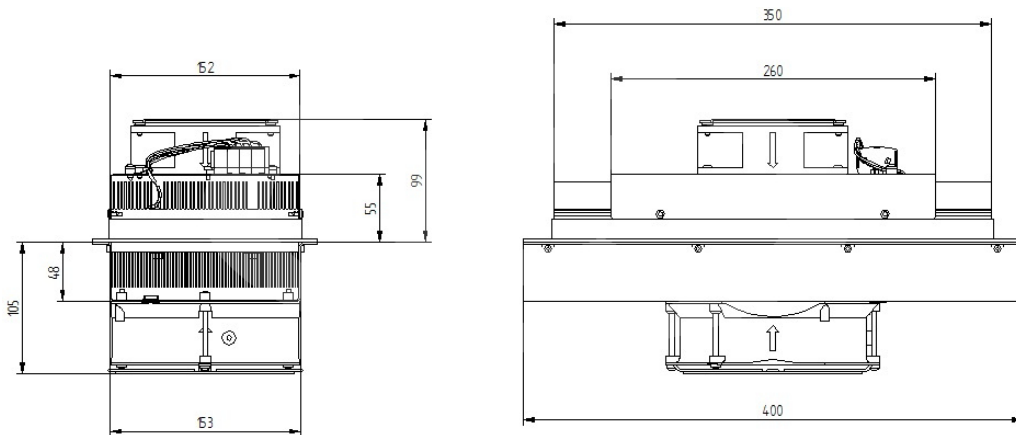
ISOMETRIC DRAWINGS

MOUNTING HOLE LOCATION & HARDWARE

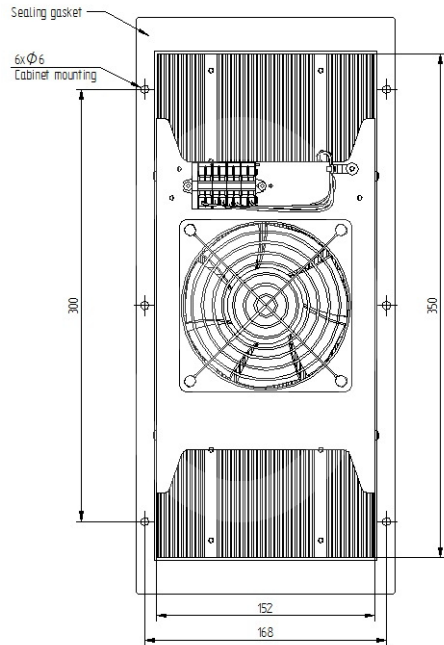

ELECTRIC CONNECTIONS 24VDC (CAGE CLAMP)

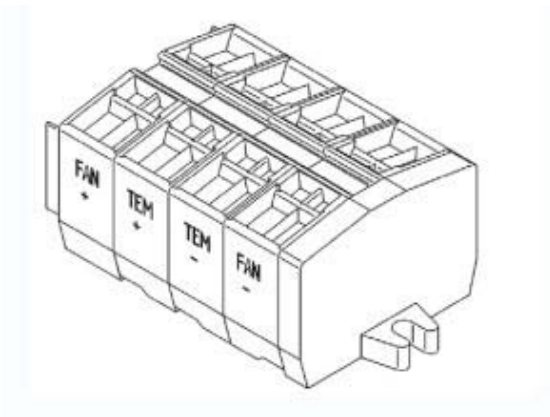

LAIRD-ETS-AA-250-24-44-00-XX-DATA-SHEET-101416

Any information furnished by Laird Technologies, Inc. and its agents is believed to be accurate and reliable. All specifications are subject to change without notice. Responsibility for the use and application of Laird Technologies materials rests with the end user. Laird Technologies makes no warranties as to the fitness, merchantability, suitability or non- infringement of any Laird Technologies materials or products for any specific or general uses. Laird Technologies shall not be liable for incidental or consequential damages of any kind. All Laird Technologies products are sold pursuant to the Laird Technologies' Terms and Conditions of sale in effect from time to time, a copy of which will be furnished upon request. © Copyright 2016 Laird Technologies, Inc. All Rights Reserved. Laird, Laird Technologies, the Laird Technologies Logo, and other marks are trademarks or registered trademarks of Laird Technologies, Inc. or an affiliate company thereof. Other product or service names may be the property of third parties. Nothing herein provides a license under any Laird Technologies or any third party intellectual property rights.