

16 A, 600 V, low drop IGBT with soft and fast recovery diode

Features

- Low on-voltage drop ($V_{CE(sat)}$)
- High current capability
- Very soft ultra fast recovery antiparallel diode

Applications

- Light dimmer
- Static relays
- Motor drive

Description

This IGBT utilizes the advanced Power MESH™ process featuring extremely low on-state voltage drop in low-frequency working conditions (up to 1 kHz).

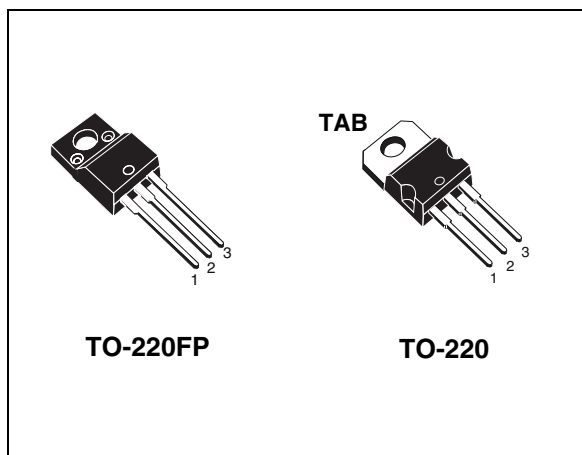

Figure 1. Internal schematic diagram

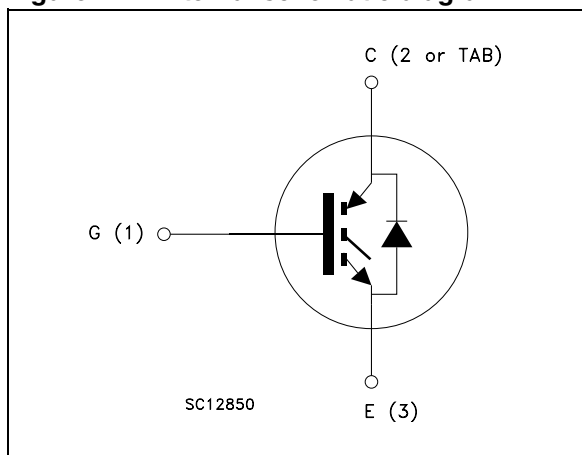

Table 1. Device summary

Order codes	Marking	Package	Packaging
STGF10NB60SD	GF10NB60SD	TO-220FP	Tube
STGP10NB60SD	GP10NB60SD	TO-220	Tube

Contents

1	Electrical ratings	3
2	Electrical characteristics	4
	2.1 Electrical characteristics (curves)	6
3	Test circuits	9
4	Package mechanical data	10
5	Revision history	14

1 Electrical ratings

Table 2. Absolute maximum ratings

Symbol	Parameter	Value		Unit
		STGF10NB60SD	STGP10NB60SD	
V _{CES}	Collector-emitter voltage (V _{GE} = 0)	600		V
I _C ⁽¹⁾	Continuous collector current at T _C = 25 °C	23	29	A
I _C ⁽¹⁾	Continuous collector current at T _C = 100 °C	12	16	A
I _{CL} ⁽²⁾	Turn-off latching current	20		A
I _{CP} ⁽³⁾	Pulsed collector current	80		A
V _{GE}	Gate-emitter voltage	±20		V
I _F	Diode RMS forward current at T _C = 25 °C	20		A
I _{FSM}	Surge non repetitive forward current t _p = 10 ms sinusoidal	55		A
V _{ISO}	Isolation withstand voltage (RMS) from all three leads to external heatsink (t=1 s; T _C = 25 °C)	2500		V
P _{TOT}	Total dissipation at T _C = 25 °C	25	80	W
T _j	Operating junction temperature	– 55 to 150		°C

1. Calculated according to the iterative formula

$$I_C(T_C) = \frac{T_{j(max)} - T_C}{R_{thj-c} \times V_{CE(sat)(max)}(T_{j(max)}, I_C(T_C))}$$

2. V_{clamp} = 80% of V_{CES}, T_j = 150 °C, R_G = 1kΩ, V_{GE} = 15 V

3. Pulse width limited by maximum junction temperature and turn-off within RBSOA

Table 3. Thermal data

Symbol	Parameter	Value		Unit
		STGF10NB60SD	STGP10NB60SD	
R _{thj-case}	Thermal resistance junction-case IGBT	5	1.56	°C/W
R _{thj-case}	Thermal resistance junction-case diode	5.6	2.2	°C/W
R _{thj-amb}	Thermal resistance junction-ambient	62.5		°C/W

2 Electrical characteristics

($T_j = 25\text{ °C}$ unless otherwise specified)

Table 4. Static

Symbol	Parameter	Test conditions	Min.	Typ.	Max.	Unit
$V_{(BR)CES}$	Collector-emitter breakdown voltage ($V_{GE} = 0$)	$I_C = 250\ \mu\text{A}$	600			V
$V_{(BR)ECS}$	Emitter-collector breakdown voltage ($V_{GE} = 0$)	$I_C = 1\ \text{mA}$	20			V
I_{GES}	Gate-emitter leakage current ($V_{CE} = 0$)	$V_{GE} = \pm 20\ \text{V}$			± 100	nA
I_{CES}	Collector cut-off current ($V_{GE} = 0$)	$V_{CE} = 600\ \text{V}$ $V_{CE} = 600\ \text{V}, T_j = 125\text{ °C}$			10 100	μA μA
$V_{GE(th)}$	Gate threshold voltage	$V_{CE} = V_{GE}, I_C = 250\ \mu\text{A}$	2.5		5	V
$V_{CE(sat)}$	Collector-emitter saturation voltage	$V_{GE} = 15\ \text{V}, I_C = 5\ \text{A}$ $V_{GE} = 15\ \text{V}, I_C = 10\ \text{A}$ $V_{GE} = 15\ \text{V}, I_C = 10\ \text{A}, T_j = 125\text{ °C}$		1.15 1.35 1.25	1.75	V
$g_{fs}^{(1)}$	Forward transconductance	$V_{CE} = 15\ \text{V}, I_C = 10\ \text{A}$	5			S

1. Pulsed: Pulse duration = 300 μs , duty cycle 1.5%

Table 5. Dynamic

Symbol	Parameter	Test conditions	Min.	Typ.	Max.	Unit
C_{ies}	Input capacitance			610		pF
C_{oes}	Output capacitance	$V_{CE} = 25\ \text{V}, f = 1\ \text{MHz}, V_{GE} = 0$	-	65	-	pF
C_{res}	Reverse transfer capacitance					
Q_g	Total gate charge	$V_{CE} = 400\ \text{V}, I_C = 10\ \text{A}, V_{GE} = 15\ \text{V}$ (see Figure 19)	-	33	-	nC

Table 6. Switching on/off (inductive load)

Symbol	Parameter	Test conditions	Min.	Typ.	Max.	Unit
$t_{d(on)}$	Turn-on delay time	$V_{CC} = 480\text{ V}, I_C = 10\text{ A}$		0.7		μs
t_r	Current rise time	$R_G = 1\text{ k}\Omega, V_{GE} = 15\text{ V}$	-	0.46	-	μs
$(di/dt)_{on}$	Turn-on current slope	(see Figure 18)		8		A/ μs
$t_r(V_{off})$	Off voltage rise time	$V_{CC} = 480\text{ V}, I_C = 10\text{ A}$		2.2		
$t_{d(off)}$	Turn-off delay time	$R_G = 1\text{ k}\Omega, V_{GE} = 15\text{ V}$	-	1.2	-	μs
t_f	Current fall time	(see Figure 18)		1.2		
$t_r(V_{off})$	Off voltage rise time	$V_{CC} = 480\text{ V}, I_C = 10\text{ A}$		3.8		
$t_{d(off)}$	Turn-off delay time	$R_G = 1\text{ k}\Omega, V_{GE} = 15\text{ V},$ $T_j = 125\text{ }^\circ\text{C}$	-	1.2	-	μs
t_f	Current fall time	(see Figure 18)		1.9		

Table 7. Switching energy (inductive load)

Symbol	Parameter	Test conditions	Min.	Typ.	Max.	Unit
$E_{on}^{(1)}$	Turn-on switching losses	$V_{CC} = 480\text{ V}, I_C = 10\text{ A}$		0.6		mJ
$E_{off}^{(2)}$	Turn-off switching losses	$R_G = 1\text{ k}\Omega, V_{GE} = 15\text{ V}$	-	5	-	mJ
E_{ts}	Total switching losses	(see Figure 18)		5.6		mJ
$E_{off}^{(2)}$	Turn-off switching losses	$V_{CC} = 480\text{ V}, I_C = 10\text{ A}$ $R_G = 1\text{ k}\Omega, V_{GE} = 15\text{ V},$ $T_j = 125\text{ }^\circ\text{C}$ (see Figure 18)	-	8	-	mJ

1. E_{on} is the turn-on losses when a typical diode is used in the test circuit. If the IGBT is offered in a package with a co-pack diode, the co-pack diode is used as external diode. IGBTs and diode are at the same temperature (25°C and 125°C)

2. Turn-off losses include also the tail of the collector current.

Table 8. Collector-emitter diode

Symbol	Parameter	Test conditions	Min	Typ.	Max	Unit
V_F	Forward on-voltage	$I_F = 10\text{ A}$ $I_F = 10\text{ A}, T_C = 125\text{ }^\circ\text{C}$		1.4	2.2	V V
t_{rr}	Reverse recovery time	$I_F = 7\text{ A}, V_R = 40\text{ V},$ $di/dt = 100\text{ A}/\mu\text{s}$ (see Figure 21)		37		ns
Q_{rr}	Reverse recovery charge			40		nC
I_{rrm}	Reverse recovery current			2.1		A
t_{rr}	Reverse recovery time	$I_F = 7\text{ A}, V_R = 40\text{ V},$ $T_j = 125\text{ }^\circ\text{C},$ $di/dt = 100\text{ A}/\mu\text{s}$ (see Figure 21)		61		ns
Q_{rr}	Reverse recovery charge			98		nC
I_{rrm}	Reverse recovery current			3.2		A

2.1 Electrical characteristics (curves)

Figure 2. Output characteristics

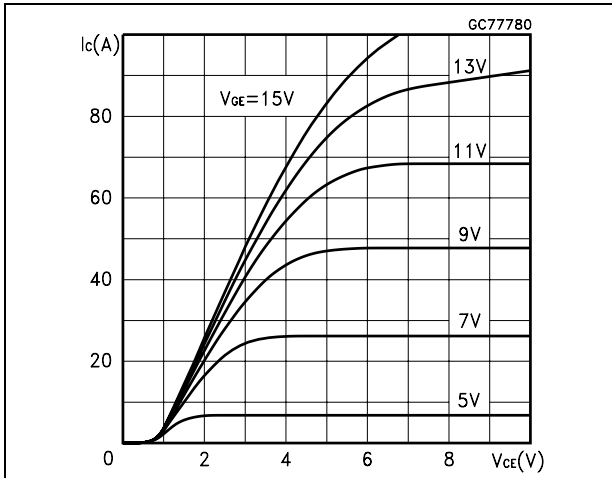

Figure 3. Transfer characteristics

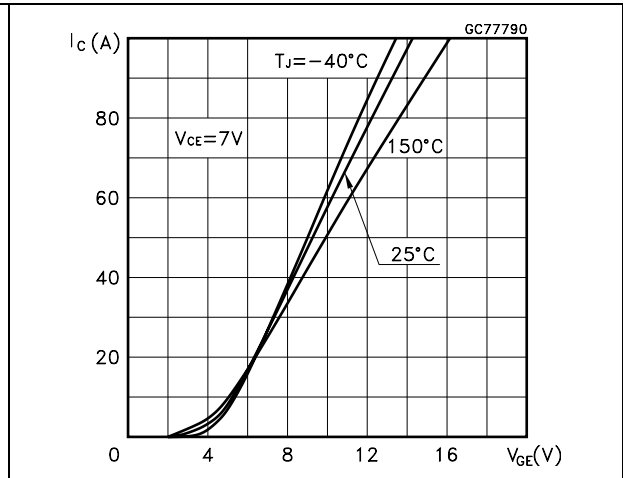

Figure 4. Transconductance

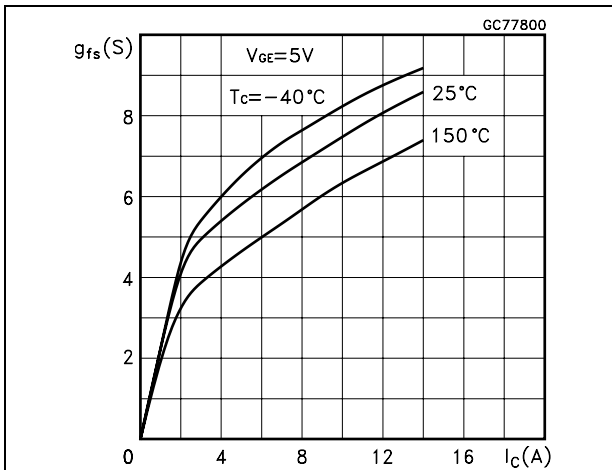

Figure 5. Collector-emitter on voltage vs. temperature

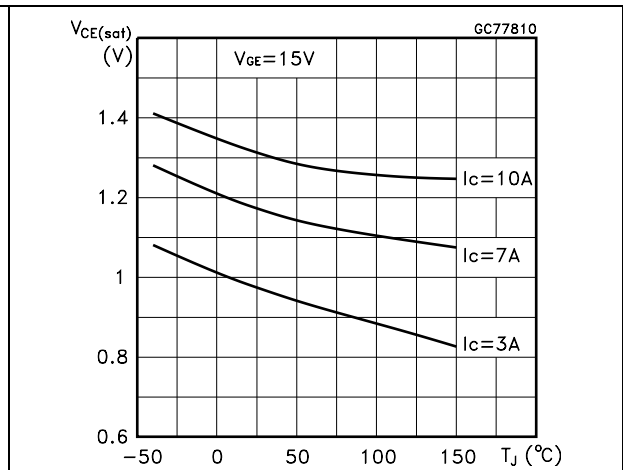

Figure 6. Collector-emitter on voltage vs. collector current

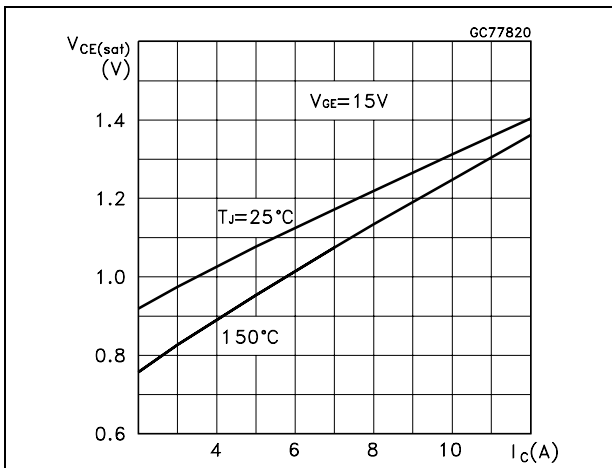

Figure 7. Normalized gate threshold vs. temperature

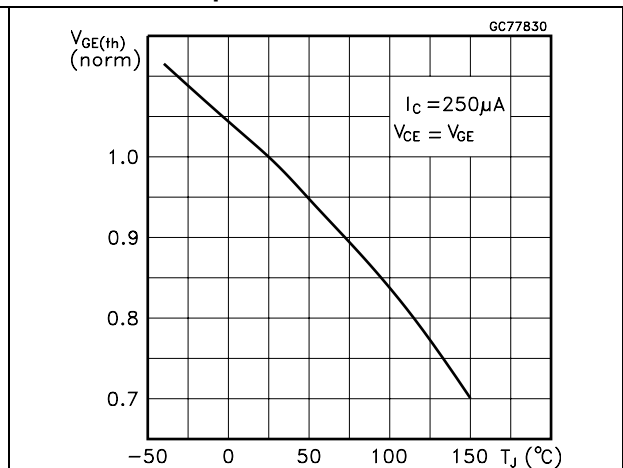

Figure 8. Normalized breakdown voltage vs. temperature

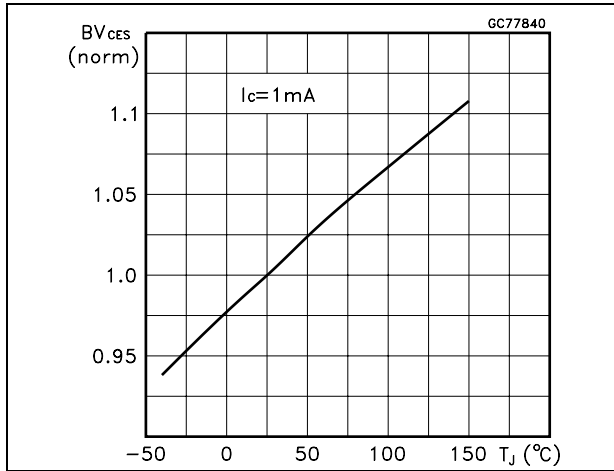

Figure 9. Gate charge vs. gate-emitter voltage

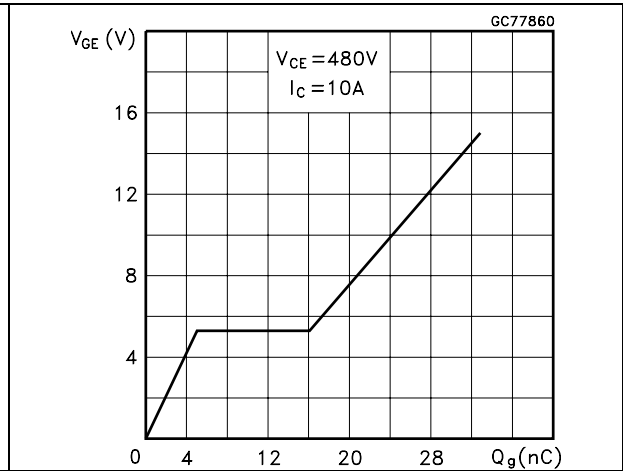

Figure 10. Capacitance variations

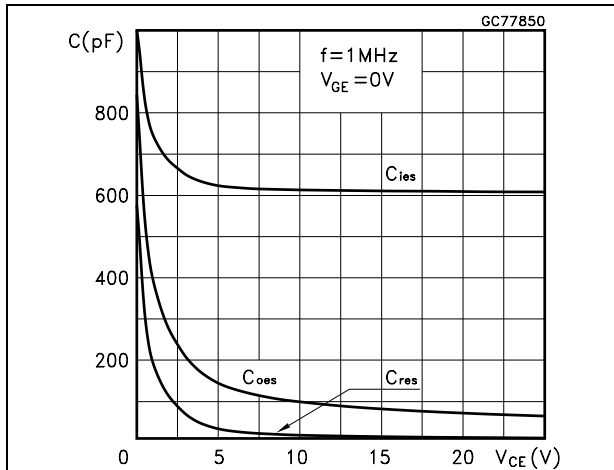

Figure 11. Switching losses vs. temperature

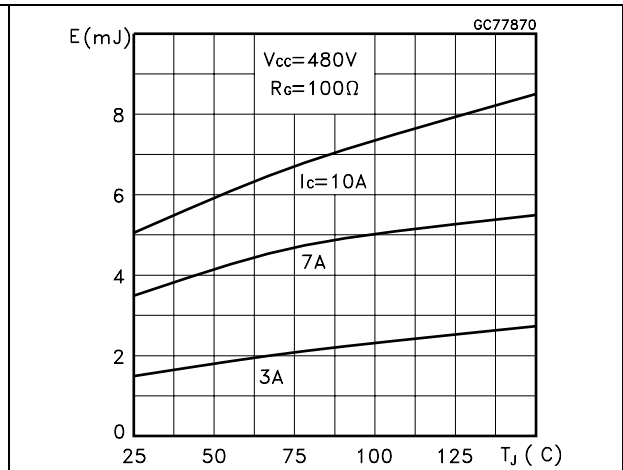

Figure 12. Switching losses vs. gate resistance

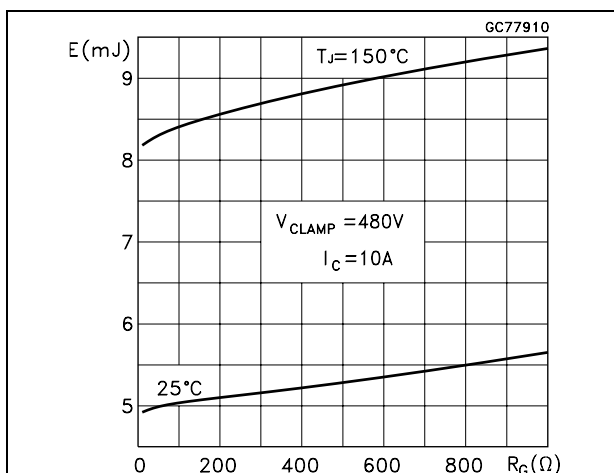

Figure 13. Switching losses vs. collector current

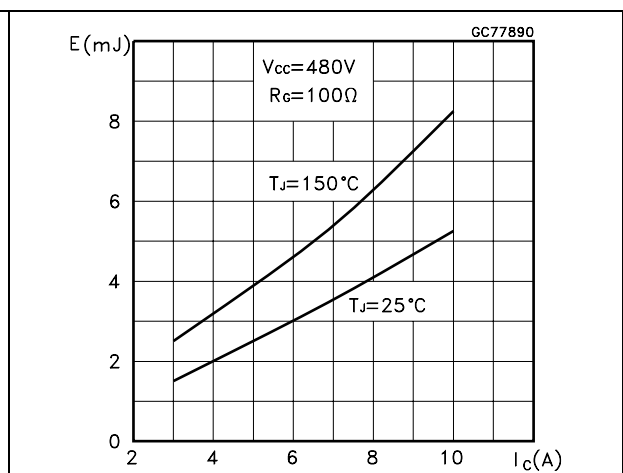

Figure 14. Thermal impedance for TO-220

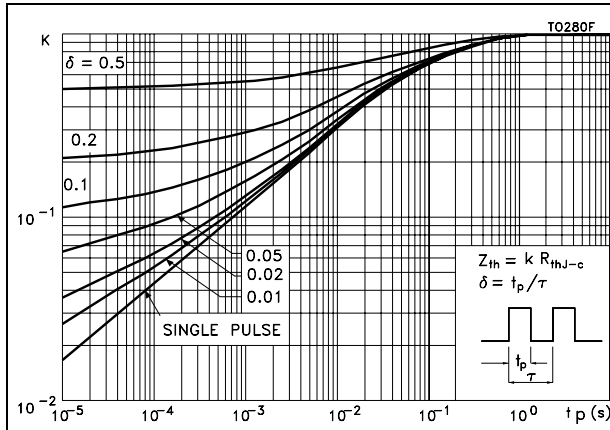

Figure 15. Thermal impedance for TO-220FP

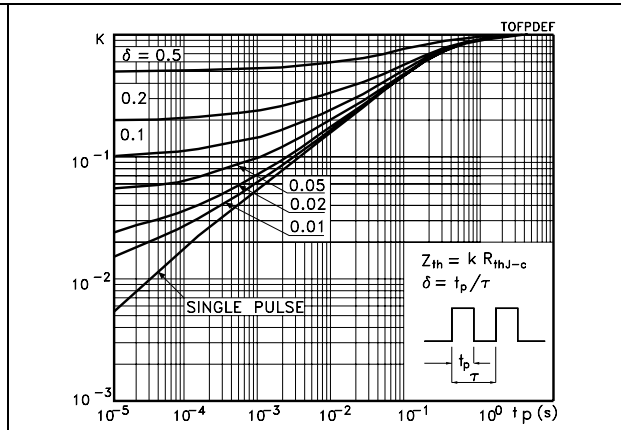

Figure 16. Turn-off SOA

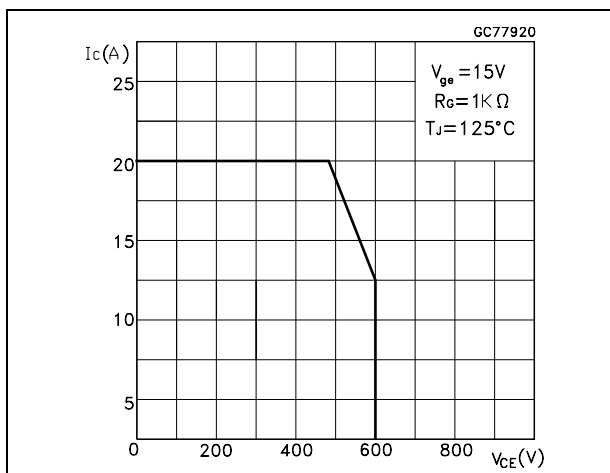
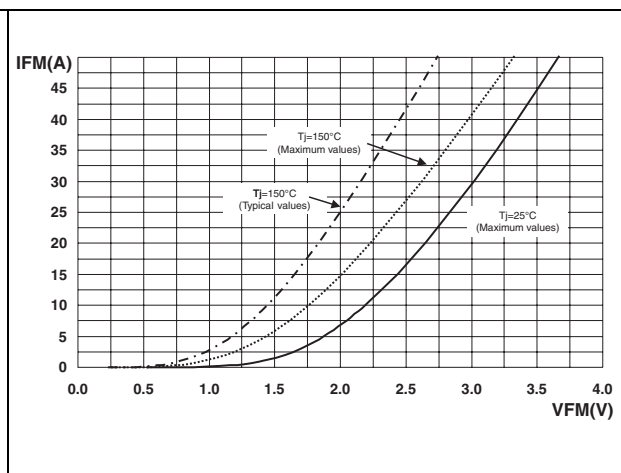

Figure 17. Forward voltage drop versus forward current



3 Test circuits

Figure 18. Test circuit for inductive load switching

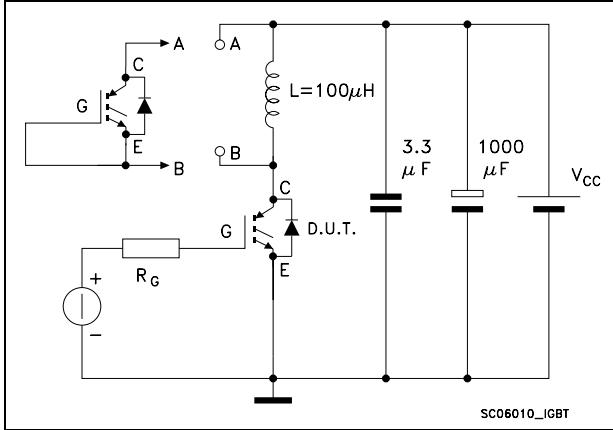

Figure 19. Gate charge test circuit

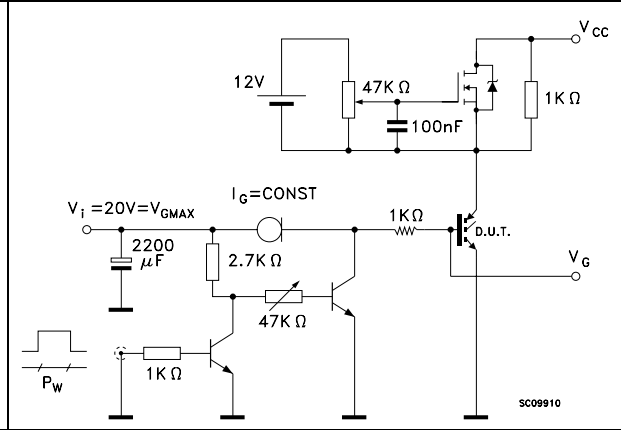

Figure 20. Switching waveforms

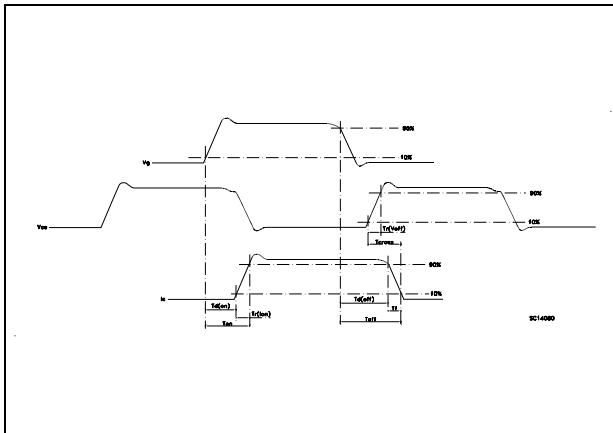
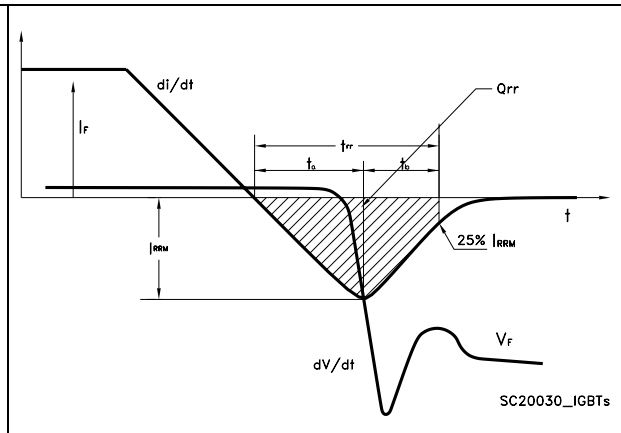

Figure 21. Diode recovery times waveform



4 Package mechanical data

In order to meet environmental requirements, ST offers these devices in different grades of ECOPACK[®] packages, depending on their level of environmental compliance. ECOPACK[®] specifications, grade definitions and product status are available at: www.st.com. ECOPACK is an ST trademark.

Table 9. TO-220FP mechanical data

Dim.	mm.		
	Min.	Typ.	Max.
A	4.4		4.6
B	2.5		2.7
D	2.5		2.75
E	0.45		0.7
F	0.75		1
F1	1.15		1.70
F2	1.15		1.70
G	4.95		5.2
G1	2.4		2.7
H	10		10.4
L2		16	
L3	28.6		30.6
L4	9.8		10.6
L5	2.9		3.6
L6	15.9		16.4
L7	9		9.3
Dia	3		3.2

Figure 22. TO-220FP drawing

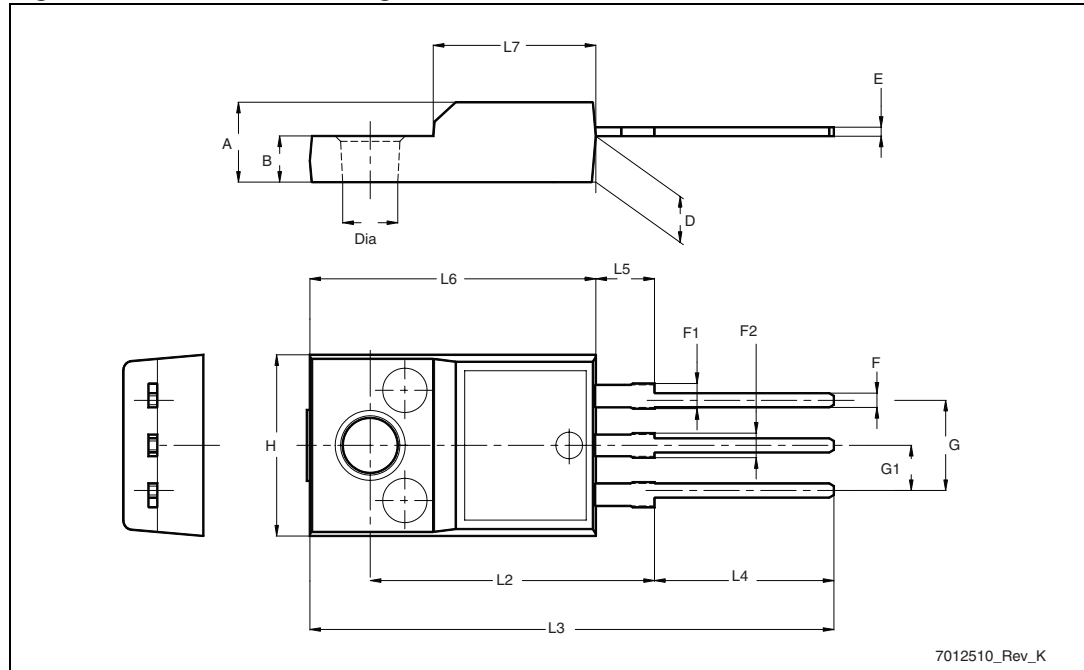
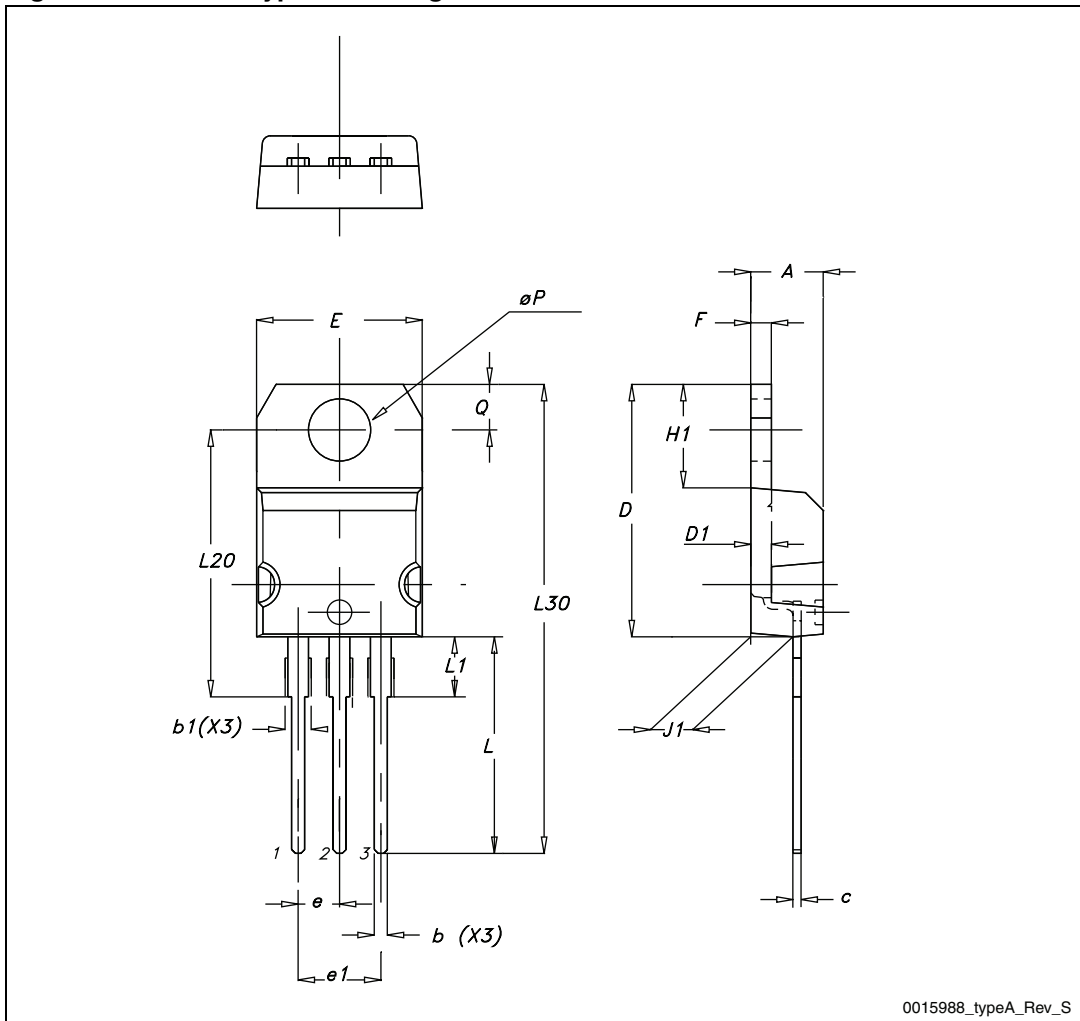

Table 10. TO-220 type A mechanical data

Dim.	mm.		
	Min.	Typ.	Max.
A	4.40		4.60
b	0.61		0.88
b1	1.14		1.70
c	0.48		0.70
D	15.25		15.75
D1		1.27	
E	10		10.40
e	2.40		2.70
e1	4.95		5.15
F	1.23		1.32
H1	6.20		6.60
J1	2.40		2.72
L	13		14
L1	3.50		3.93
L20		16.40	
L30		28.90	
∅P	3.75		3.85
Q	2.65		2.95

Figure 23. TO-220 type A drawing



5 Revision history

Table 11. Document revision history

Date	Revision	Changes
18-Nov-2005	1	New release.
16-Dec-2010	2	Inserted device in TO-220FP. Updated Table 2: Absolute maximum ratings , Table 8: Collector-emitter diode and packages mechanical data Section 4: Package mechanical data .
22-Sep-2011	3	Modified: unit value Table 7 on page 5 , Figure 2 and Figure 3 on page 6 .

Please Read Carefully:

Information in this document is provided solely in connection with ST products. STMicroelectronics NV and its subsidiaries ("ST") reserve the right to make changes, corrections, modifications or improvements, to this document, and the products and services described herein at any time, without notice.

All ST products are sold pursuant to ST's terms and conditions of sale.

Purchasers are solely responsible for the choice, selection and use of the ST products and services described herein, and ST assumes no liability whatsoever relating to the choice, selection or use of the ST products and services described herein.

No license, express or implied, by estoppel or otherwise, to any intellectual property rights is granted under this document. If any part of this document refers to any third party products or services it shall not be deemed a license grant by ST for the use of such third party products or services, or any intellectual property contained therein or considered as a warranty covering the use in any manner whatsoever of such third party products or services or any intellectual property contained therein.

UNLESS OTHERWISE SET FORTH IN ST'S TERMS AND CONDITIONS OF SALE ST DISCLAIMS ANY EXPRESS OR IMPLIED WARRANTY WITH RESPECT TO THE USE AND/OR SALE OF ST PRODUCTS INCLUDING WITHOUT LIMITATION IMPLIED WARRANTIES OF MERCHANTABILITY, FITNESS FOR A PARTICULAR PURPOSE (AND THEIR EQUIVALENTS UNDER THE LAWS OF ANY JURISDICTION), OR INFRINGEMENT OF ANY PATENT, COPYRIGHT OR OTHER INTELLECTUAL PROPERTY RIGHT.

UNLESS EXPRESSLY APPROVED IN WRITING BY TWO AUTHORIZED ST REPRESENTATIVES, ST PRODUCTS ARE NOT RECOMMENDED, AUTHORIZED OR WARRANTED FOR USE IN MILITARY, AIR CRAFT, SPACE, LIFE SAVING, OR LIFE SUSTAINING APPLICATIONS, NOR IN PRODUCTS OR SYSTEMS WHERE FAILURE OR MALFUNCTION MAY RESULT IN PERSONAL INJURY, DEATH, OR SEVERE PROPERTY OR ENVIRONMENTAL DAMAGE. ST PRODUCTS WHICH ARE NOT SPECIFIED AS "AUTOMOTIVE GRADE" MAY ONLY BE USED IN AUTOMOTIVE APPLICATIONS AT USER'S OWN RISK.

Resale of ST products with provisions different from the statements and/or technical features set forth in this document shall immediately void any warranty granted by ST for the ST product or service described herein and shall not create or extend in any manner whatsoever, any liability of ST.

ST and the ST logo are trademarks or registered trademarks of ST in various countries.

Information in this document supersedes and replaces all information previously supplied.

The ST logo is a registered trademark of STMicroelectronics. All other names are the property of their respective owners.

© 2011 STMicroelectronics - All rights reserved

STMicroelectronics group of companies

Australia - Belgium - Brazil - Canada - China - Czech Republic - Finland - France - Germany - Hong Kong - India - Israel - Italy - Japan - Malaysia - Malta - Morocco - Philippines - Singapore - Spain - Sweden - Switzerland - United Kingdom - United States of America

www.st.com